

Film Clearing in Practice

Filmmuseum – The Netherlands

Géraldine Vooren (Legal Counsel - Images for the Future)
Eric Palmen (Historian)



Amsterdam, May 31th 2011



The Practice of Clearing



The Practice of Clearing

- Finding Right Holders



The Practice of Clearing

- Finding Right Holders
 - The Pyramid



The Practice of Clearing

- Finding Right Holders
 - The Pyramid
 - An Example



The Practice of Clearing

- Finding Right Holders
 - The Pyramid
 - An Example
- Rights Management System



The Practice of Clearing

- Finding Right Holders
 - The Pyramid
 - An Example
- Rights Management System
 - Aims



The Practice of Clearing

- Finding Right Holders
 - The Pyramid
 - An Example
- Rights Management System
 - Aims
 - Functional Design



The Practice of Clearing

- Finding Right Holders
 - The Pyramid
 - An Example
- Rights Management System
 - Aims
 - Functional Design
 - Let's Have A Look



Finding Right Holders: The Pyramid

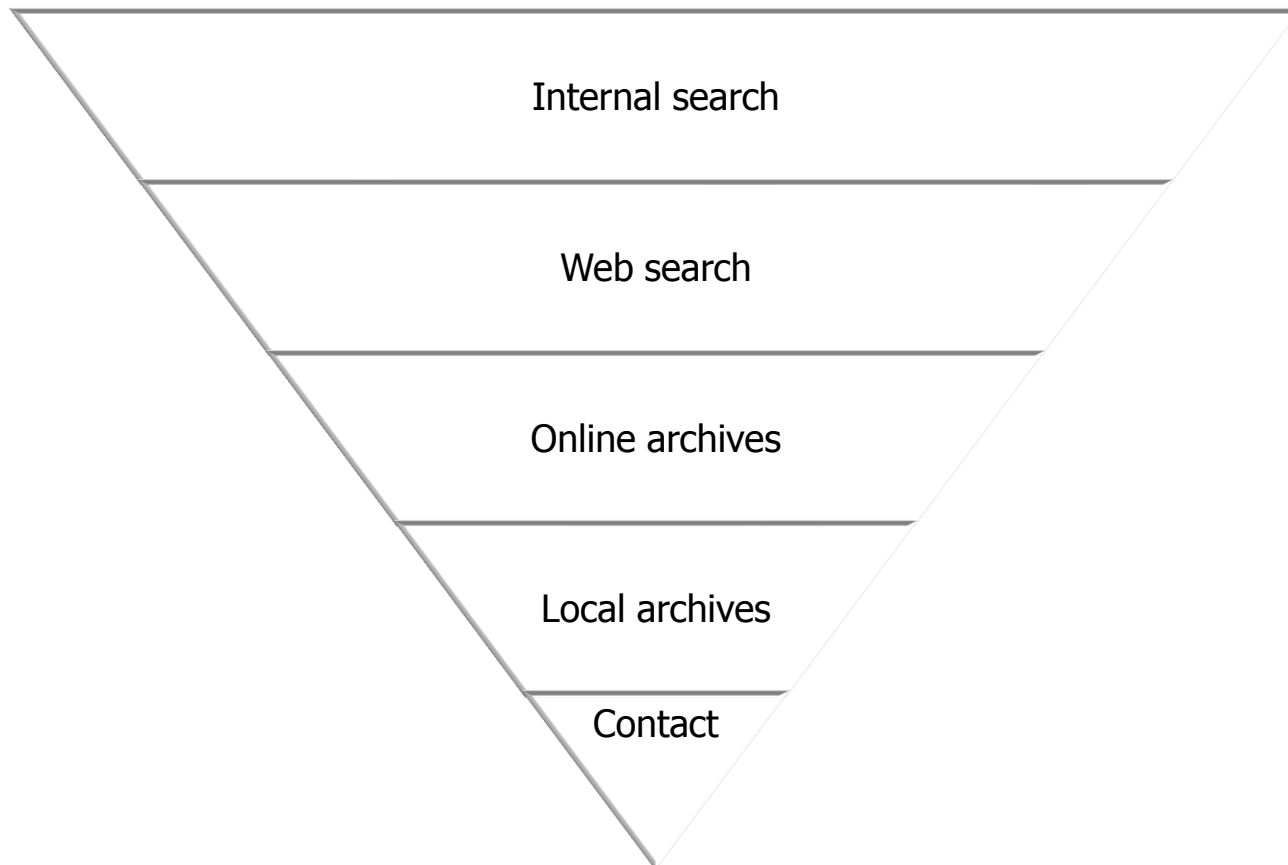

Finding Right Holders: The Pyramid

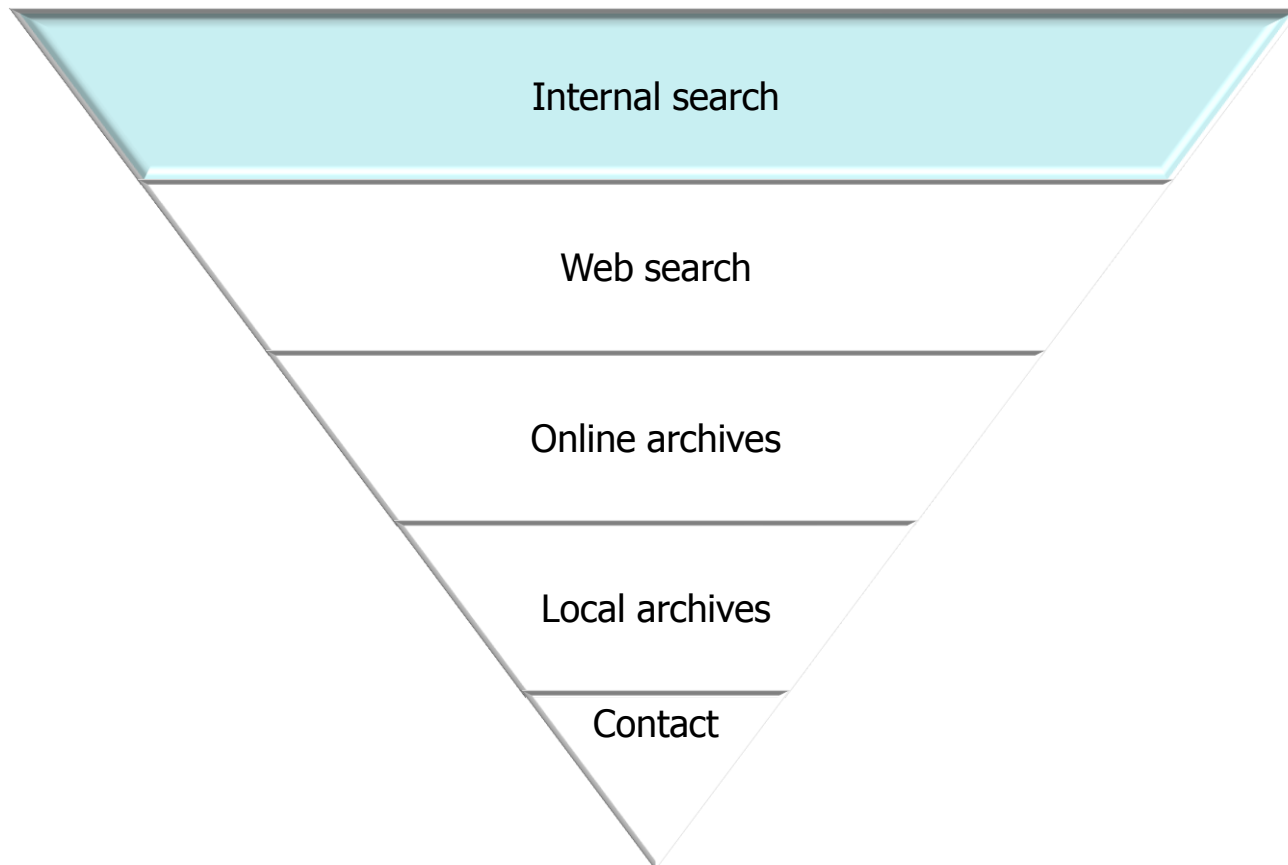

Finding Right Holders: The Pyramid

FMDB database

ALS TWEE DRUPPELS WATER (1963)

Scenario naar: collaboraties
 dubbelgangers
 Muziek/dans: verzet
 Componist: Willem Frederik Hermans

Geluid: Juriaan Andriessen
 Originele kleur: Geluid
 Origineel formaat: Zwart-wit
 Keuringslengte: 35mm
 Speelduur: 3229
 Bronnen: 116

Er zijn **kopieën** aanwezig: [58](#), [59](#), [933534](#), [933535](#), [933536](#), [933537](#), [C684](#), [C695](#), [C4378](#), [C4385](#), [D1228](#), [D2727](#), [D5810](#), [D7222](#), [D7558](#), [D7710](#), [D8193](#), [D8710](#), [DIGI1507](#), [E460](#), [FILE4005](#), [FILE8218](#), [LTO1](#)

Er is geen digitale kopie aanwezig

Er zijn **affiches** aanwezig:

Er zijn **relaties** aanwezig:

Productiejaa: 1967
 Premiere data: 1
 Keuringsdat: 1
 Aanvrager Keurn: HAFBO - Holland-America Film Booking
 Nederlandse verth: HAFBO - Holland-America Film Booking

Toelichting D / V / D

3 Ongewijzigd: 3/16416



Finding Right Holders: The Pyramid

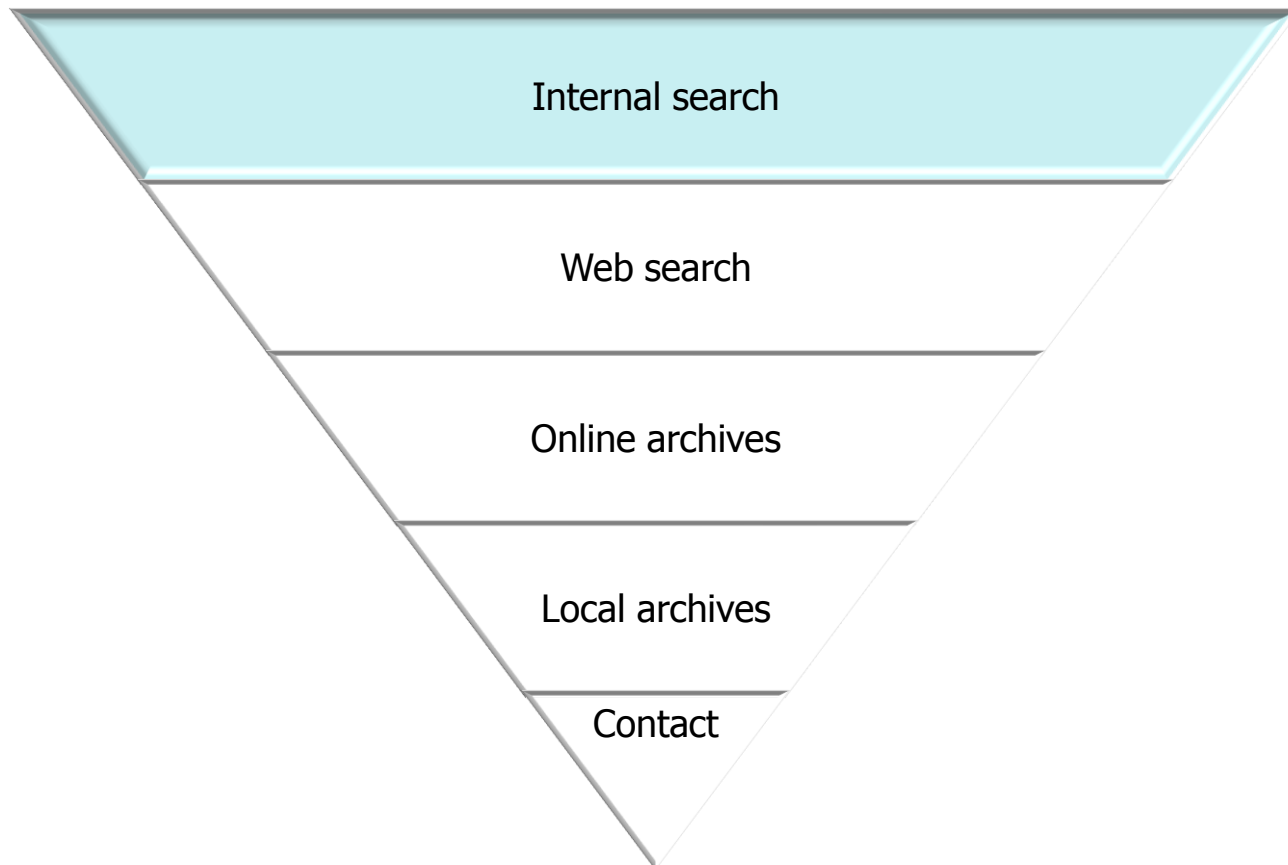

Finding Right Holders: The Pyramid

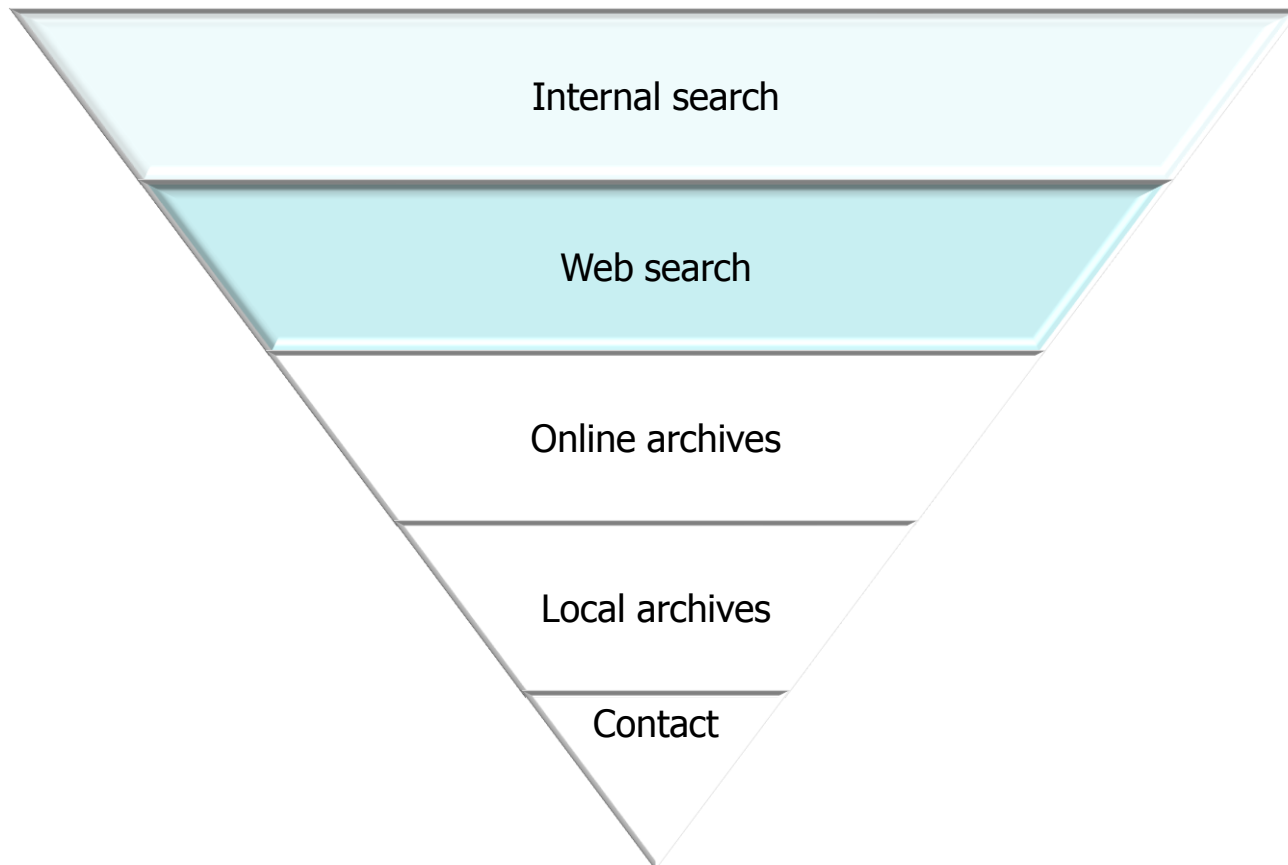

Finding Right Holders: The Pyramid

The screenshot shows the Cinema Context website interface. At the top, there is a navigation bar with the following items: "Go", "nsmi-1's Account | Logout | Help", and "NEW! Your Watchlist". Below this is a red header with the text "CINEMA CONTEXT" and a price tag of "\$83.6M". The main navigation menu includes "films", "bioscopen", "voorstellingen", "personen", "bedrijven", and "home". The main content area features a large illustration of the Rembrandt Theater building with the text "Film in Nederland vanaf 1896" and "een encyclopedie van de filmcultuur". To the right of the illustration is a smaller image of a film poster for "42 STREET" featuring Bebe Daniels, Warner Baxter, and Ruby Keeler. Below the poster is a section titled "Cijfers" (Statistics) with the following data:

- 10655 voorstellingen
- 45765 films
- 1604 bioscopen
- 29197 keuringsdossiers
- 4231

At the bottom left, there is a search bar with the text "Zoeken [zoek]" and a "Waar" label. On the far left, there is a sidebar with the text "NEDERLANDS FILM FESTIVAL" and a menu with items: "Publiek", "Indus", "Home", "Festiva", "Home", "Achtergrond", "Bladeren", "Uitgebreid zoeken", "Extra's", "Colofon", "Help", and "English".



Finding Right Holders: The Pyramid

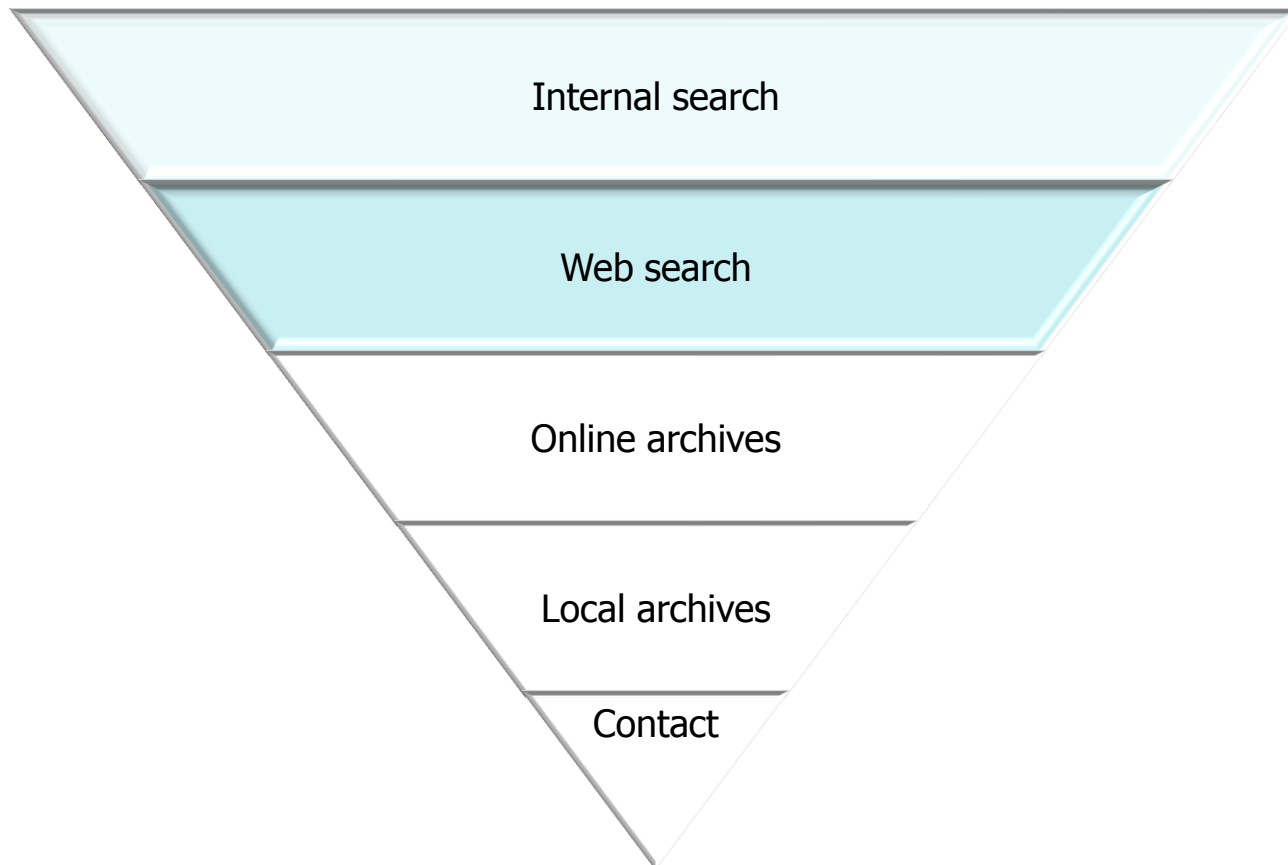

Finding Right Holders: The Pyramid

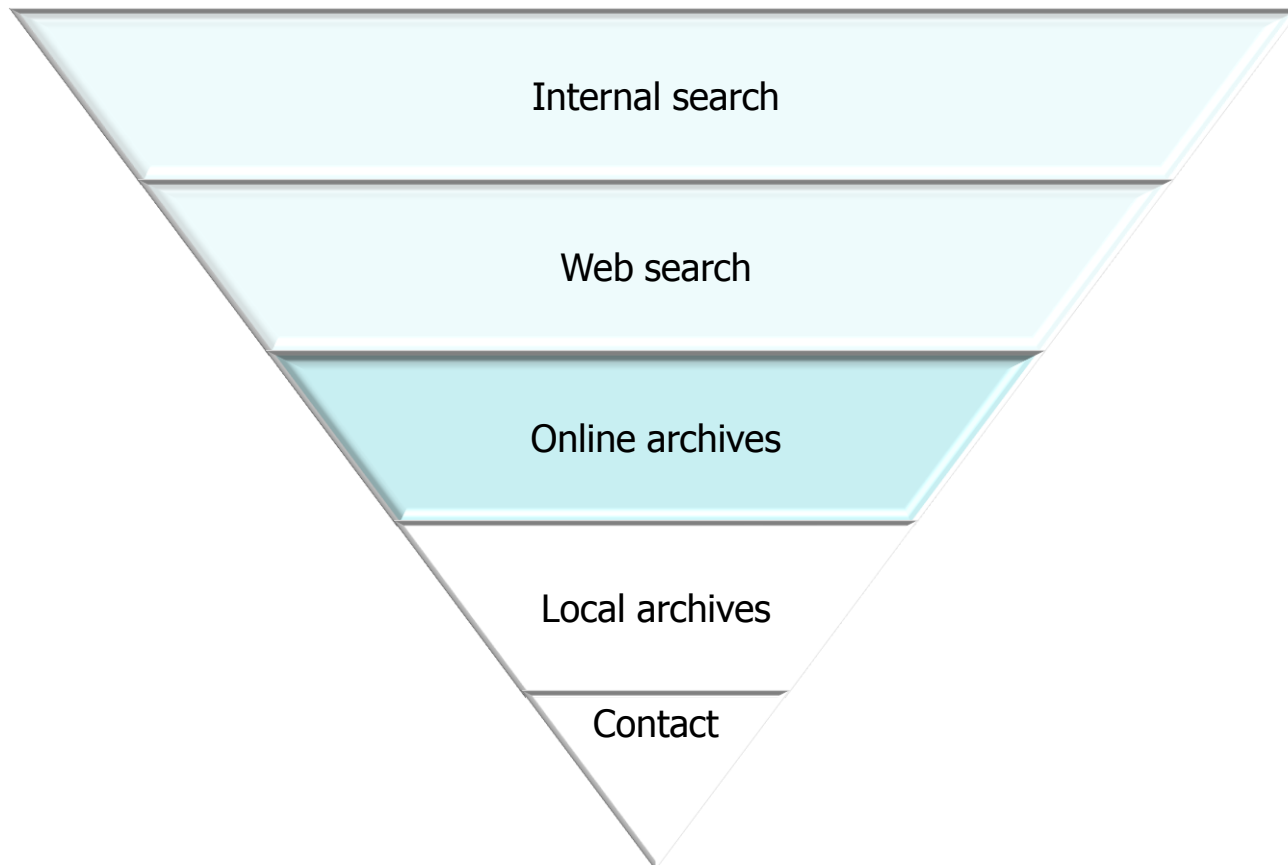

Findina Right Holders: The Pyramid

Sitemap | E-mail



FAMILYSEARCH

Discover

Records Trees

First Names
eric

Place

Search

Browse by Location

- Africa
- Asia and Middle East
- Australia and New Zealand
- Caribbean, Central America
- Europe
- Pacific Islands



Home **Biografieën** Foto Galleries Video Galleries Bob's pagina



Herman en Aaf Bouber

HERMAN BOUBER

(Amsterdam 24-9-1885 Amsterdam 2-2-1963)

Leven tussen acht en elf

Herman Blom, zich noemende en schrijvende Herman Bouber, werd geboren als zoon van het ongehuwde dienstmeisje Elisabeth Bouber, dat, zwanger van de zoon des huizes, op staande voet ontslag kreeg. Herman werd daarom geregistreerd onder zijn moeder's meisjesnaam. De naam Blom kreeg hij van een latere stiefvader, die hem echtte. Een dronkelap, aan wie Herman een gloeiende hekel had.

Hij groeide op in het hartje van de Jordaan en leerde er op de ambachtschool het vak van huisschilder. Op zijn 22ste trouwde hij met Aafje ten Hoope, een aankomende actrice, die van de vele mooie vrouwenrollen, die haar man zou schrijven, onvergetelijke creaties maakte.

Als overbekend toneelechtpaar kregen zij de erenaam "De Boubers". Herman was een eenvoudig mens. Bescheiden, integer, zachtaardig en wars van alle buitenkant en humbug. "Laat het maar zien tussen acht en elf", was zijn motto. Bezeten van zijn vak, altijd bezig. In zijn atelier met decors en kostuums, thuis alle rollen eigenhandig uitschrijvend. Maar hoe eenvoudig en zachtaardig ook in zijn werk moest je niet

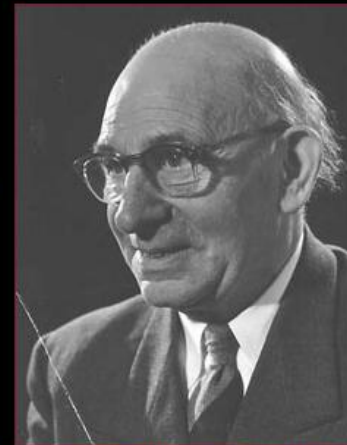

Herman Bouber in de jaren '60

Subscribe Help

Memberships

tree:

out your parents
n a guess can help.

ncestry.com for new
r family.

m Hints in your
something.

Finding Right Holders: The Pyramid

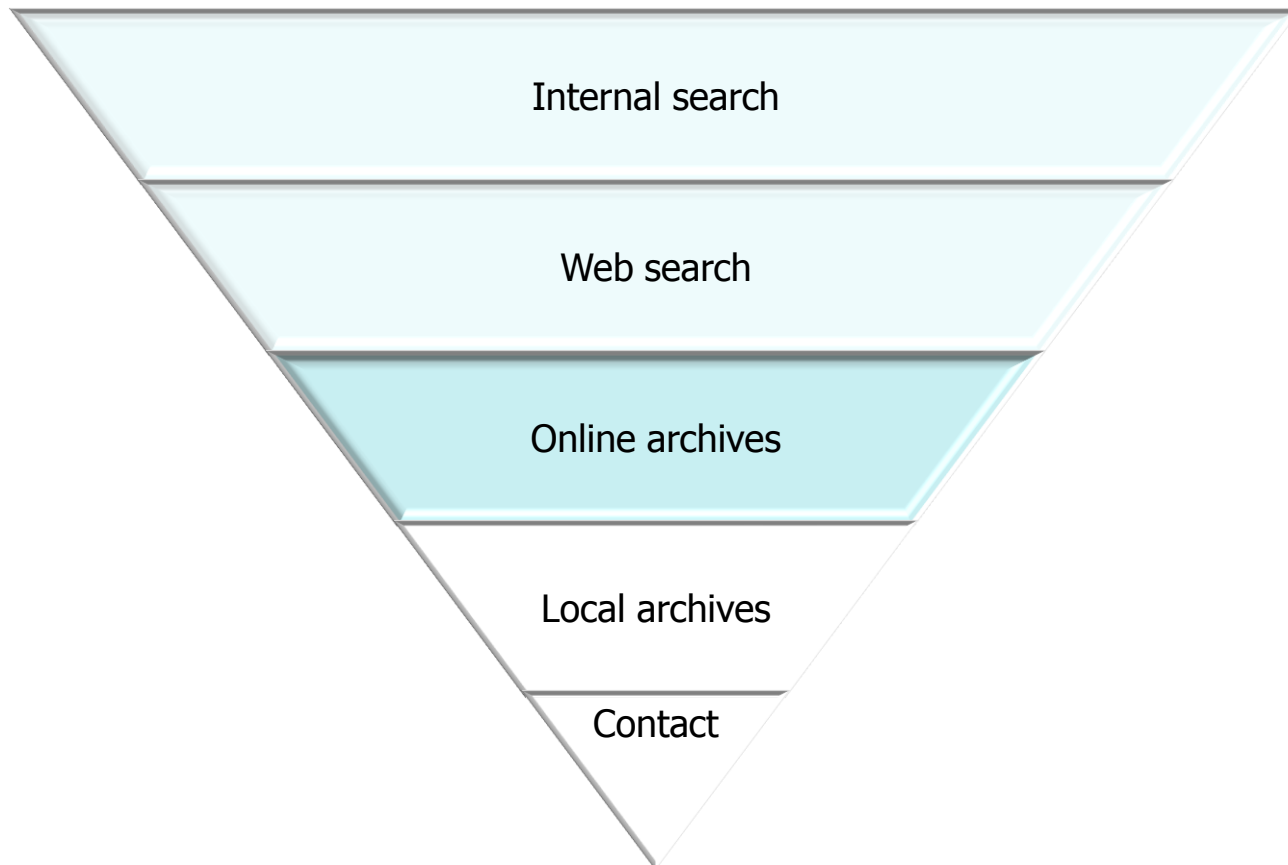

Finding Right Holders: The Pyramid

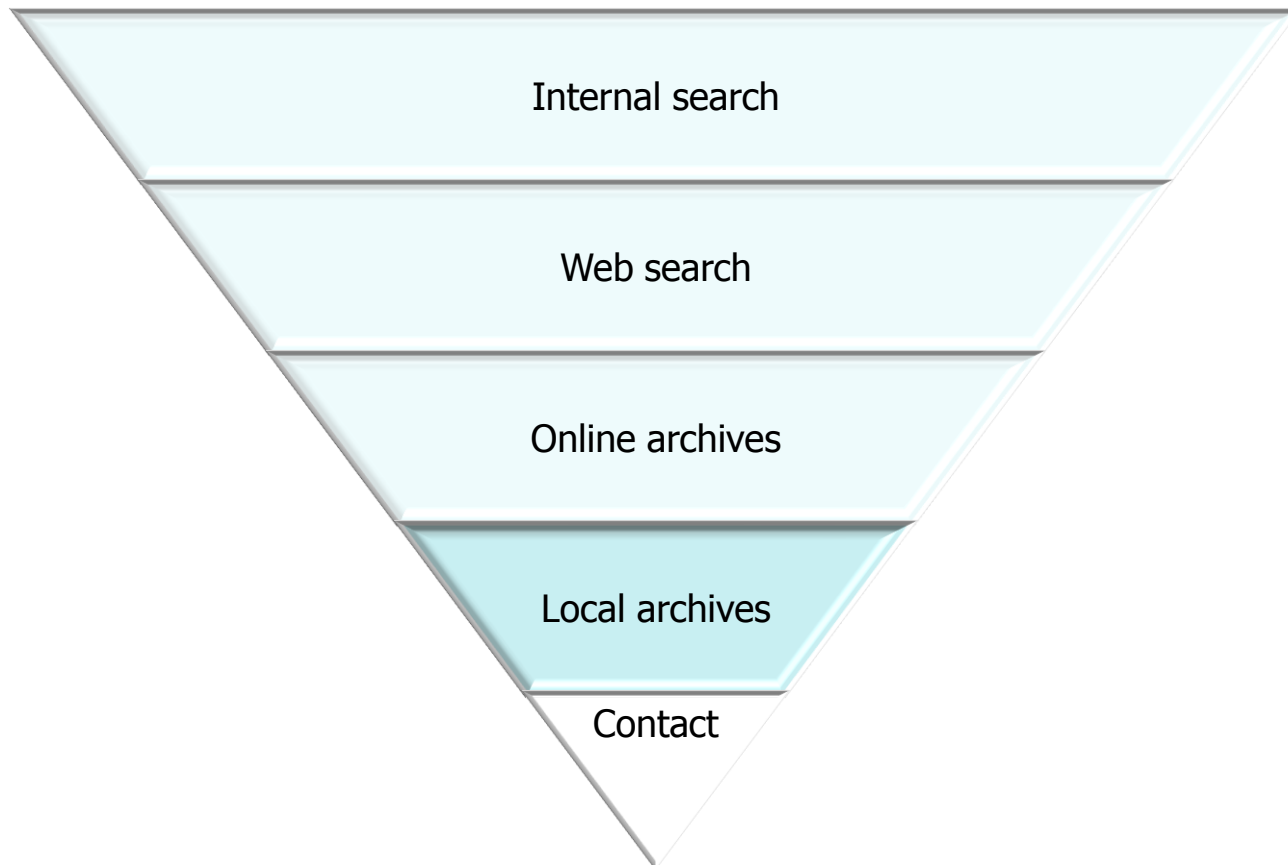

Finding Right Holders: The Pyramid



Finding Right Holders: The Pyramid

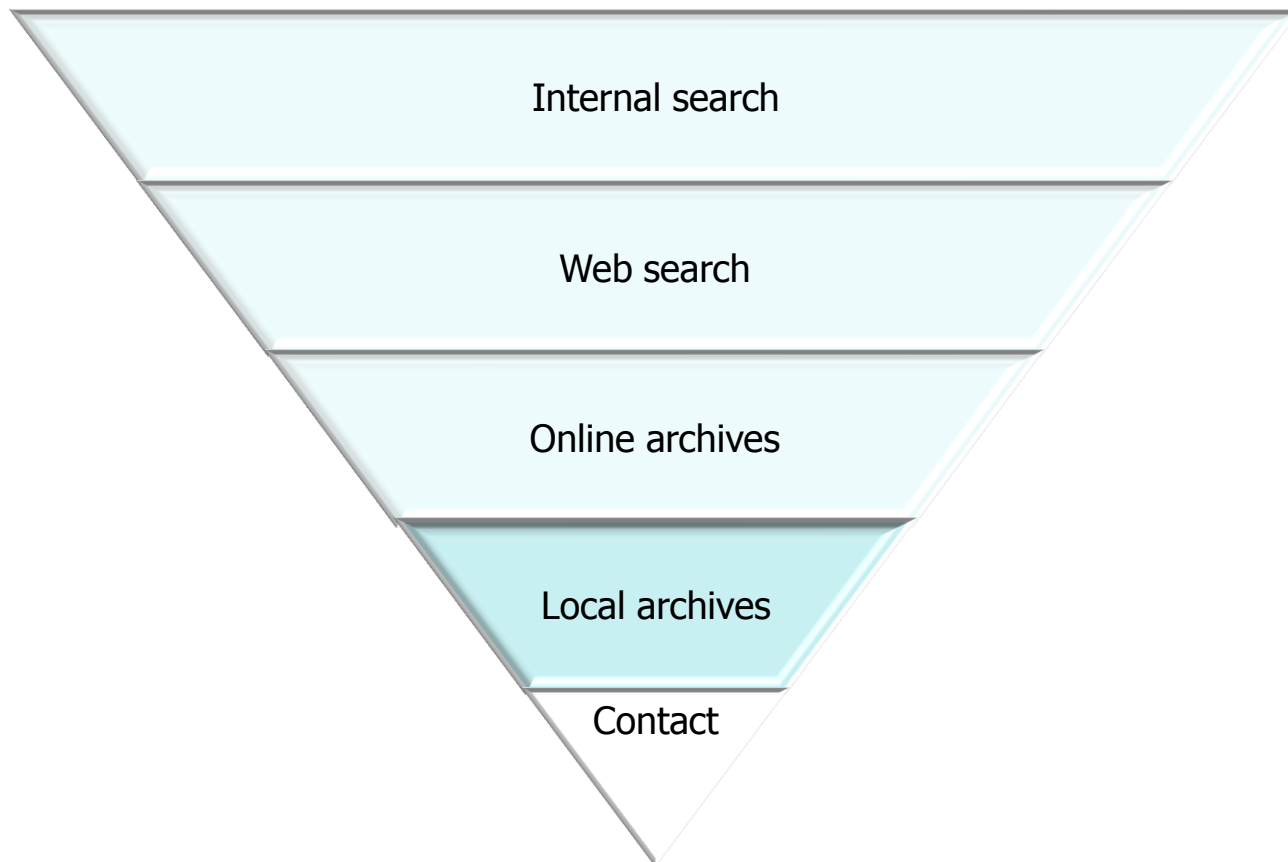

Finding Right Holders: The Pyramid

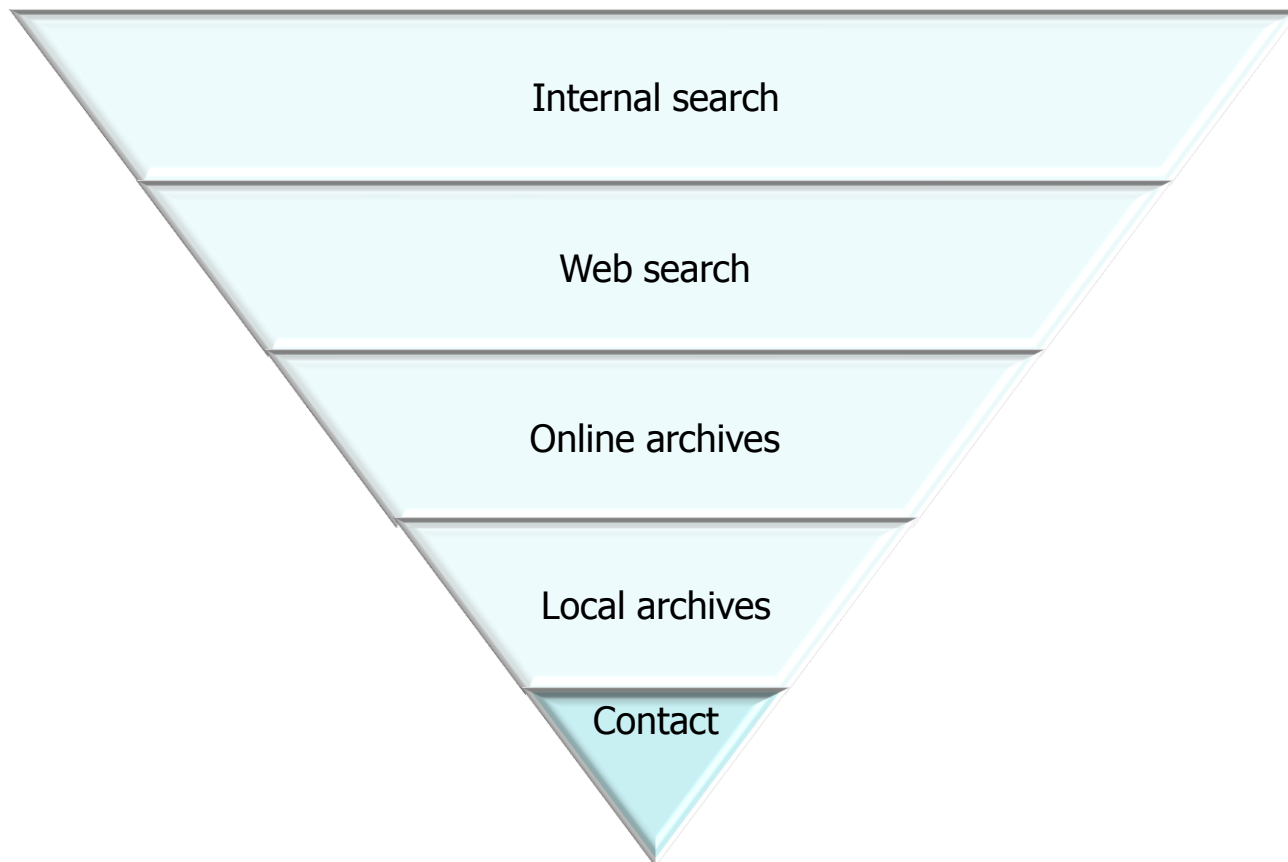

Finding Right Holders: An Example

4: Vertonen Personen

ID	4881	Opties
Naam	Loet C. Barnstijn	Eris
Familienaam	Barnstijn	Autorisatie
Tussenvoegsels		
Voornamen	Lodewijk	
Voorletters	L.	
Roepnaam	Loet	
Geslacht	Man	
Ook bekend als	Loet Cohen Barnstijn	
ID-Info		
Dateringen		
Geboortedatum	22 juni 1880	
Sterfdatum	25 december 1953	
	<input type="checkbox"/> Biografie	
Verwijzingen (pers)		
	Ed. Cohen Barnstijn	
	Ies Cohen Barnstijn	
Verwijzingen (corp)		
	HAP Film-Company (Den Haag)	
	Maatschappij tot Exploitatie van Witte Fil	
Catalogus		

Toevoegen
Dupliceren
Wijzigen
Verwijderen

Ok
Sluiten

3 Ongewijzigd: 3/4881 ID is actief



Finding Right Holders: An Example



Home	Publicaties	Lopend onderzoek	Instituut	Contact	Nederlands - English
------	-------------	------------------	-----------	---------	----------------------

Huygens Instituut voor Nederlandse Geschiedenis > Onderzoek > Publicaties

© ING – Den Haag. Bronvermelding: M. Linnemann, 'Cohen, Lodewijk (1880-1953)', in *Biografisch Woordenboek van Nederland*. URL: <http://www.inghist.nl/Onderzoek/Projecten/BWN/lemmata/bwn4/cohen> [13-03-2008]

[reactie](#)

COHEN, Lodewijk (1880-1953)

Cohen, Lodewijk, (bekend onder de naam **Loet C. Barnstijn**), ondernemer en filmpionier (Enschede 19-6-1880 - Kings Point (New York, Verenigde Staten) 25-12-1953) . Zoon van Hertog Izak Cohen, slager, later eigenaar van een meubelzaak, en Eva Barnstijn. Gehuwd op 19-12-1906 met Margaretha Frijda. Uit dit huwelijk werd 1 zoon geboren. Na echtscheiding (7-8-1911) gehuwd op 24-6-1915 met Paulina Jeanne Henriette Maria van Houten. Uit dit huwelijk werden 2 dochters geboren. Na echtscheiding (4-6-1946) gehuwd op 16-6-1946 met Hilda Duboff. Uit dit huwelijk werden geen kinderen geboren. Op 7-6-1948 verkreeg hij, onder de naam Loet Cordell Barnstijn, het Amerikaanse staatsburgerschap.

Loet Cohen groeide op in de textielstad Enschede. Na hier de lagere en middelbare school te hebben bezocht, vertrok hij - met niet meer dan 'een briefje van vijftientig en twee gouden manchetknopen' op zak (Reijnhout, 18) - op 24-jarige leeftijd naar Den Haag. Hij was er werkzaam in de textielbranche en bracht het al snel van bediende tot koopman. In 1910 begon hij een bedrijf dat zich specialiseerde in het bedrukken van stoffen. Hoewel de zaken voorspoedig gingen, besloot hij omstreeks 1912 plotseling de fabriek van de hand te doen om zijn geluk te beproeven in het bioscoopwezen. Deze bedrijfstak was aan het begin van de eeuw sterk in opkomst, nadat vaste filmtheaters de voorstellingen op kermissen hadden verdrongen. 'Ik droomde mij gouden bergen', zo motiveerde hij zijn keuze later.

Loet C. Barnstijn - zoals Cohen zich inmiddels, ter onderscheiding van anderen met die naam, naar zijn moeder was gaan noemen - begon een bioscoop in een drukke Haagse winkelstraat. Zijn concurrenten bestreed hij door middel van krachtige advertentiecampagnes en het uitdelen van presentjes aan bezoekers. Weldra kreeg hij een tweede filmtheater in handen. Problemen met de gemeentelijke keuringscommissie en het



Finding Right Holders: An Example

C. Barnstijn, Lodewijk (Loet)

[Additional information](#)

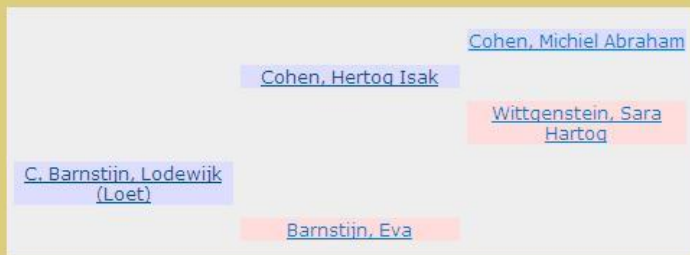

Parents

Father: [Cohen, Hertoq Isak](#)
Mother: [Barnstijn, Eva](#)

Events

Birth

Date: 22 jun 1880
Place: Enschede

Death

Date: 25 dec 1953
Place: Kings Point N.Y.

Relationship

Relation to [Paulina Jeanne Henriette Maria, van Houten](#)
24 jun 1915 Marriage; Place: Den Haag

Children of C. Barnstijn, Lodewijk (Loet) and Paulina Jeanne Henriette Maria, van Houten

[Barnstijn, Eveline Charlotte \(Lotty\)](#) (19 sep 1915)
[Barnstijn, Louise Charlotte \(Loekie\)](#) (21 jul 1918)

Relation to [Strijda, Margaretha](#)
19 dec 1906 Marriage; Place: Den Haag

Children of C. Barnstijn, Lodewijk (Loet) and Strijda, Margaretha
[C. Barnstijn \(Barns\), Hans \(Hal\)](#) (24 jun 1908)

Relation to [Duboff, Hilda](#)
16 jun 1946 Marriage;



[Picture 1](#) [Picture 2](#)



Finding Right Holders: An Example

Bestand Bewerken Beeld Favorieten Extra

Favorieten Aanbevolen websites (2) Aanbevolen websites EYE Intranet Google Historische Kranten Nederlands Film Festival Stadsarchief Amsterdam The Internet Movie Databas...

CBG Digitale studiezaal Startpagina Fee

Digitale studiezaal
Gebruiker: Eric Palmen
Tegood: 84 eenheden
English

home
zoekresultaat
eerder bekeken
eenheden kopen
aanschafhistorie
vriend worden
uw gegevens
reglement
uitloggen

Familieadvertenties tot 1970, Barnstijn
[vorige pagina](#) 11 [volgende pagina](#) [download](#)

Enige en algemene kennisgeving
Hiermede vervullen wij de droeve plicht u kennis te geven van het plotseling verscheiden op Eerste Kerstdag j.l. te Kings Point, New York, van onze goede vader, behuwd- en grootvader, de heer
LOET. C. BARNSTIJN
in de ouderdom van 74 jaar.
Namens de familie in Nederland:
L. Ch. Donkers—C. Barnstijn
H. B., Donkers.
Amstelveen, 26 December 1953.
Keizer Karelweg 392.



Finding Right Holders: An Example

Parenteel van Lodewijk Cohen

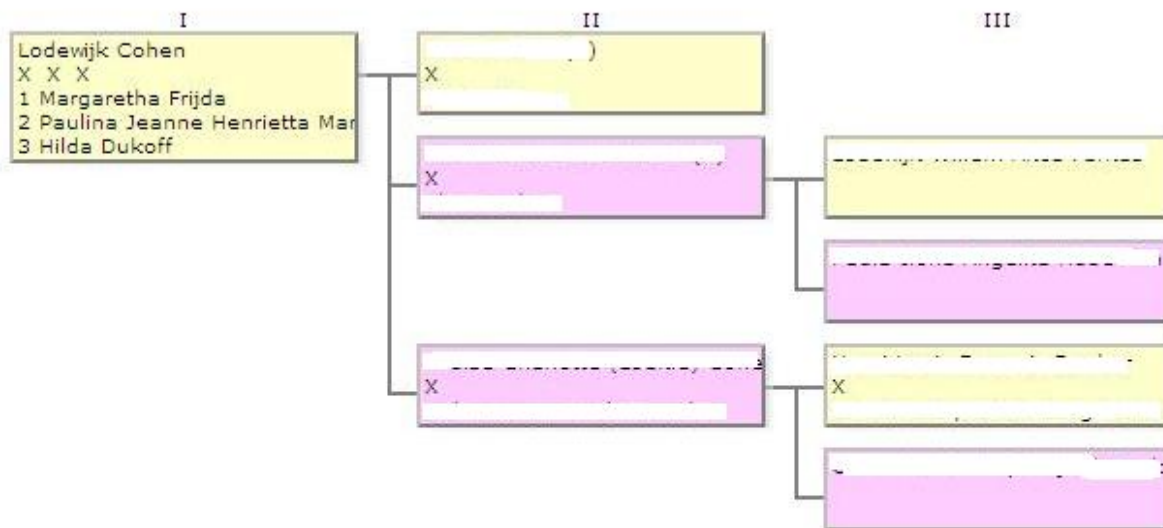

Gegenereerd met Aldfaer versie 4.1 op 02-05-2011 12:55

Man Vrouw M/V



Finding Right Holders: An Example

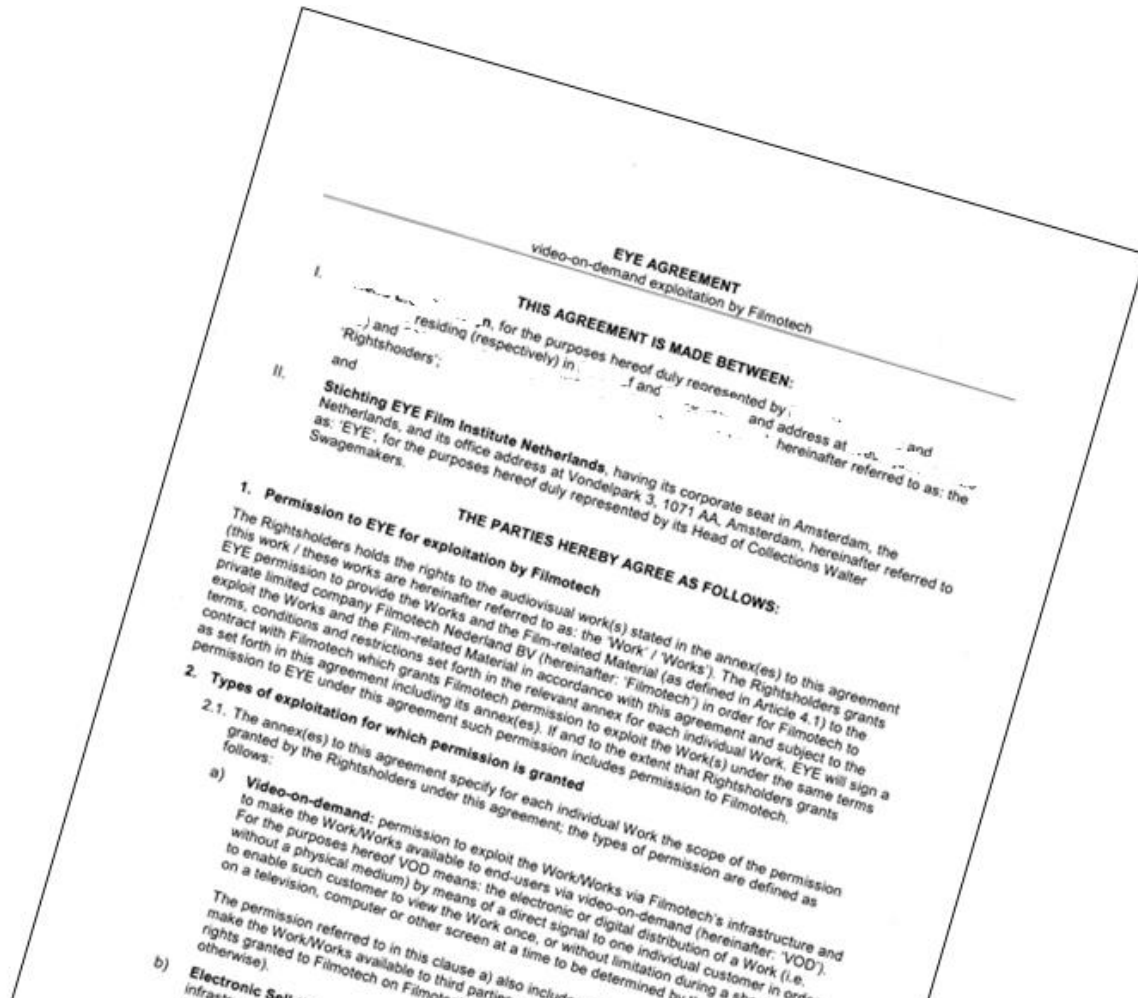

RMS: aims



RMS: aims

- To Preserve knowledge



RMS: aims

- To Preserve knowledge
- To Archive agreements



RMS: Functional Design

Film



RMS: Functional Design

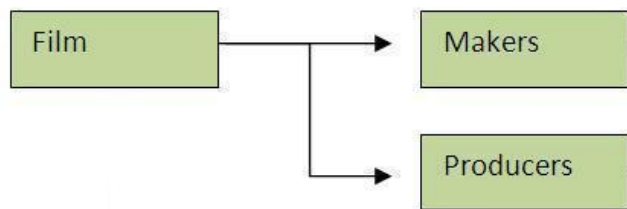

RMS: Functional Design

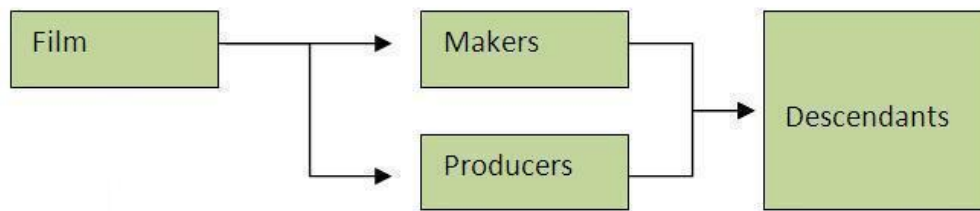

RMS: Functional Design

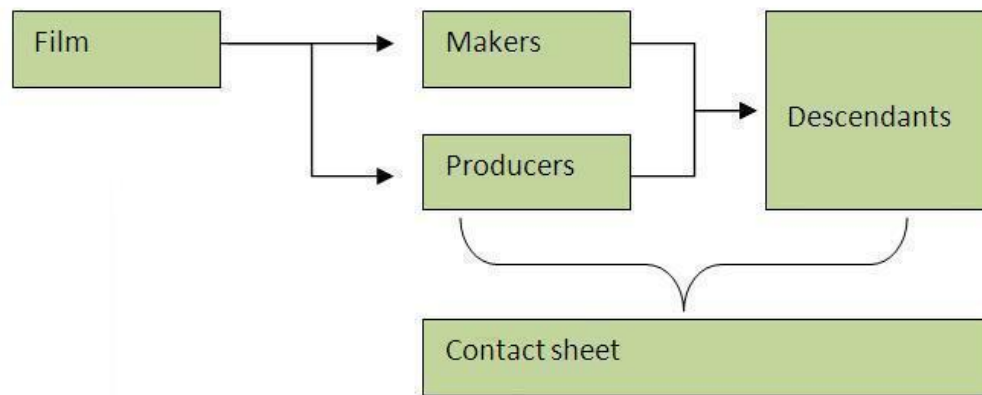

RMS: Functional Design

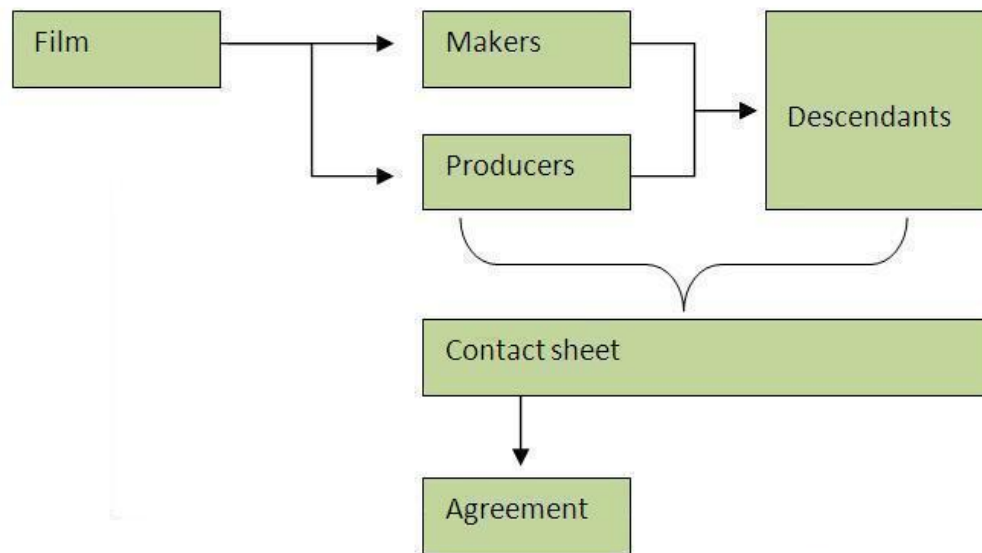

RMS: Functional Design

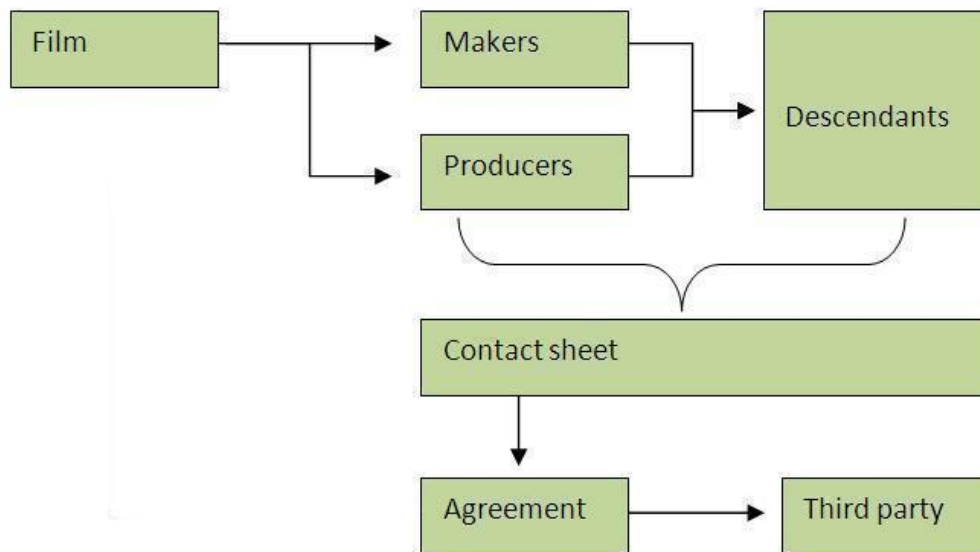

RMS: Functional Design

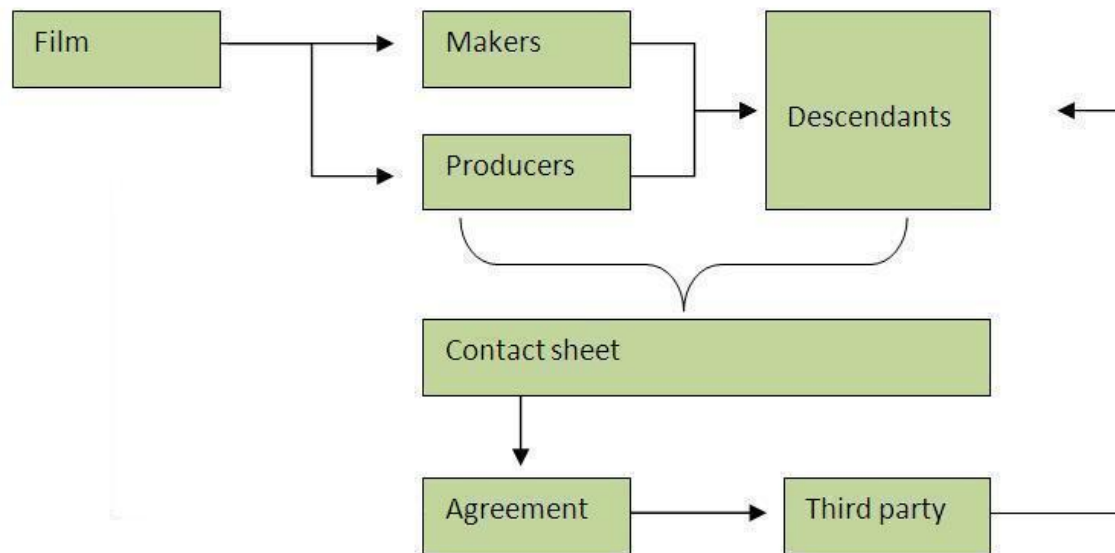

RMS: Functional Design

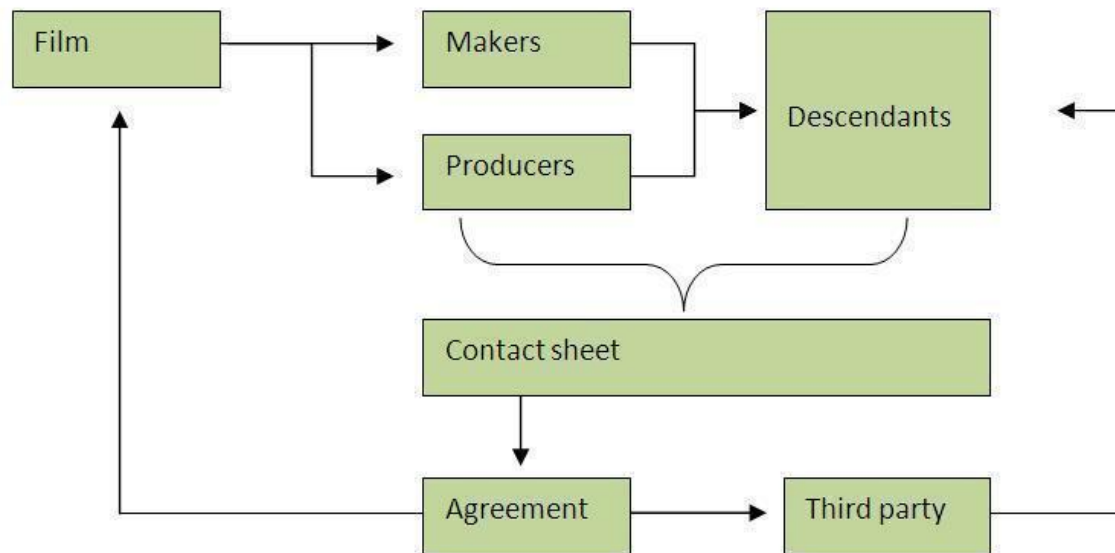

RMS: Functional Design

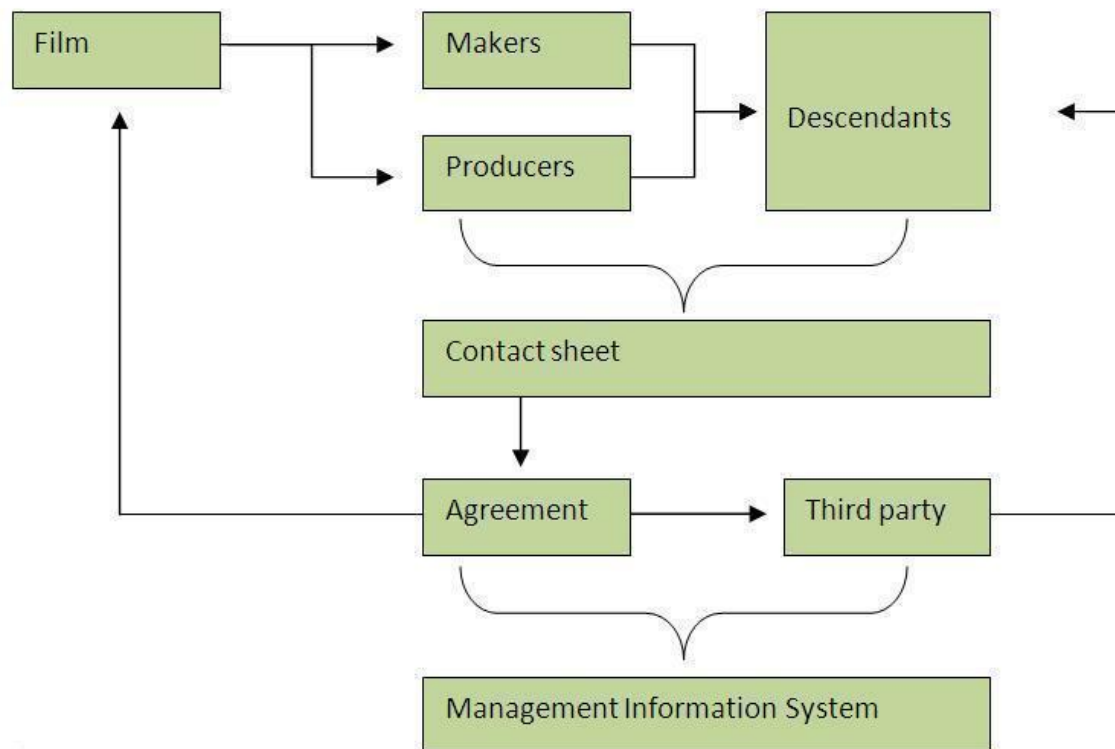

RMS: Functional Design

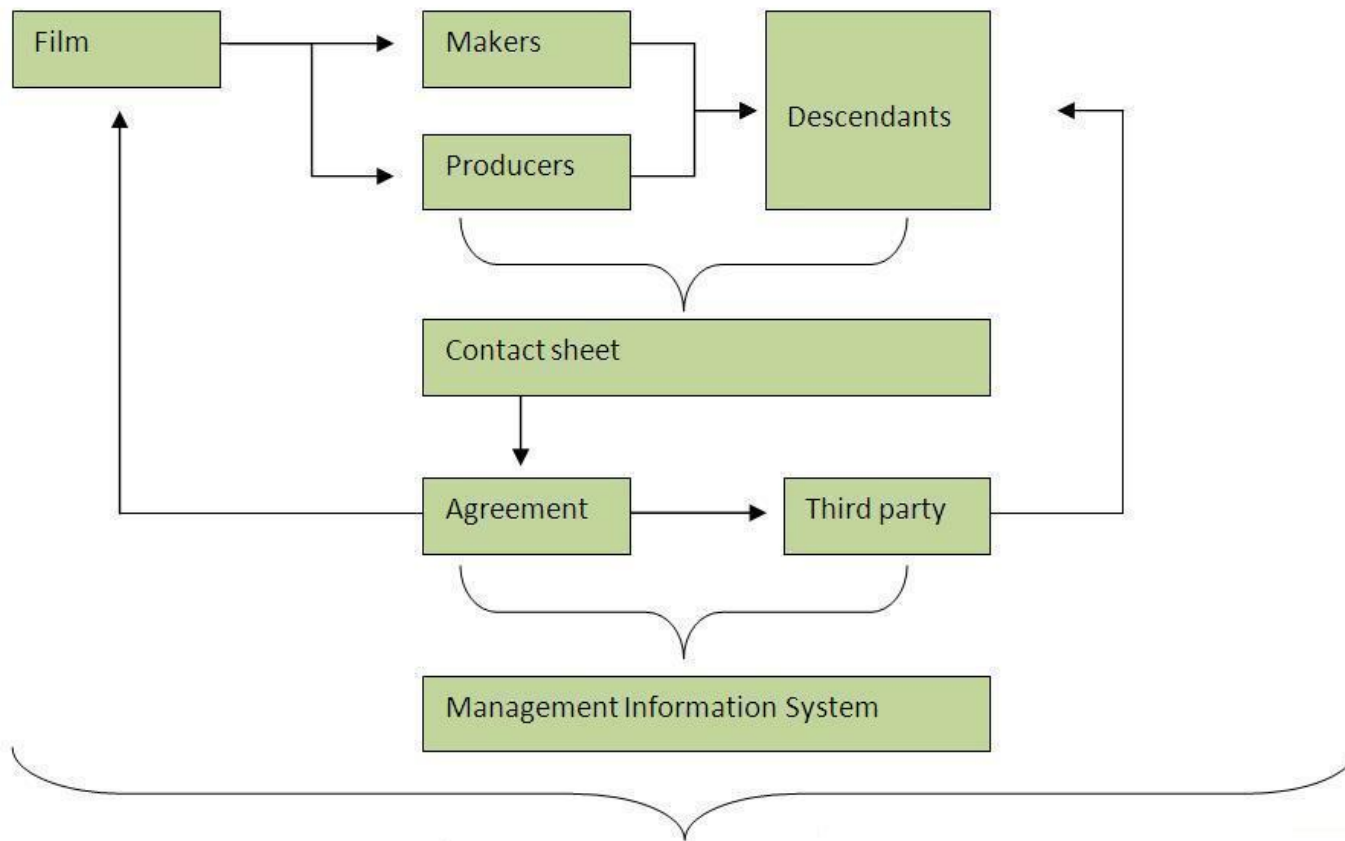

RMS: Functional Design

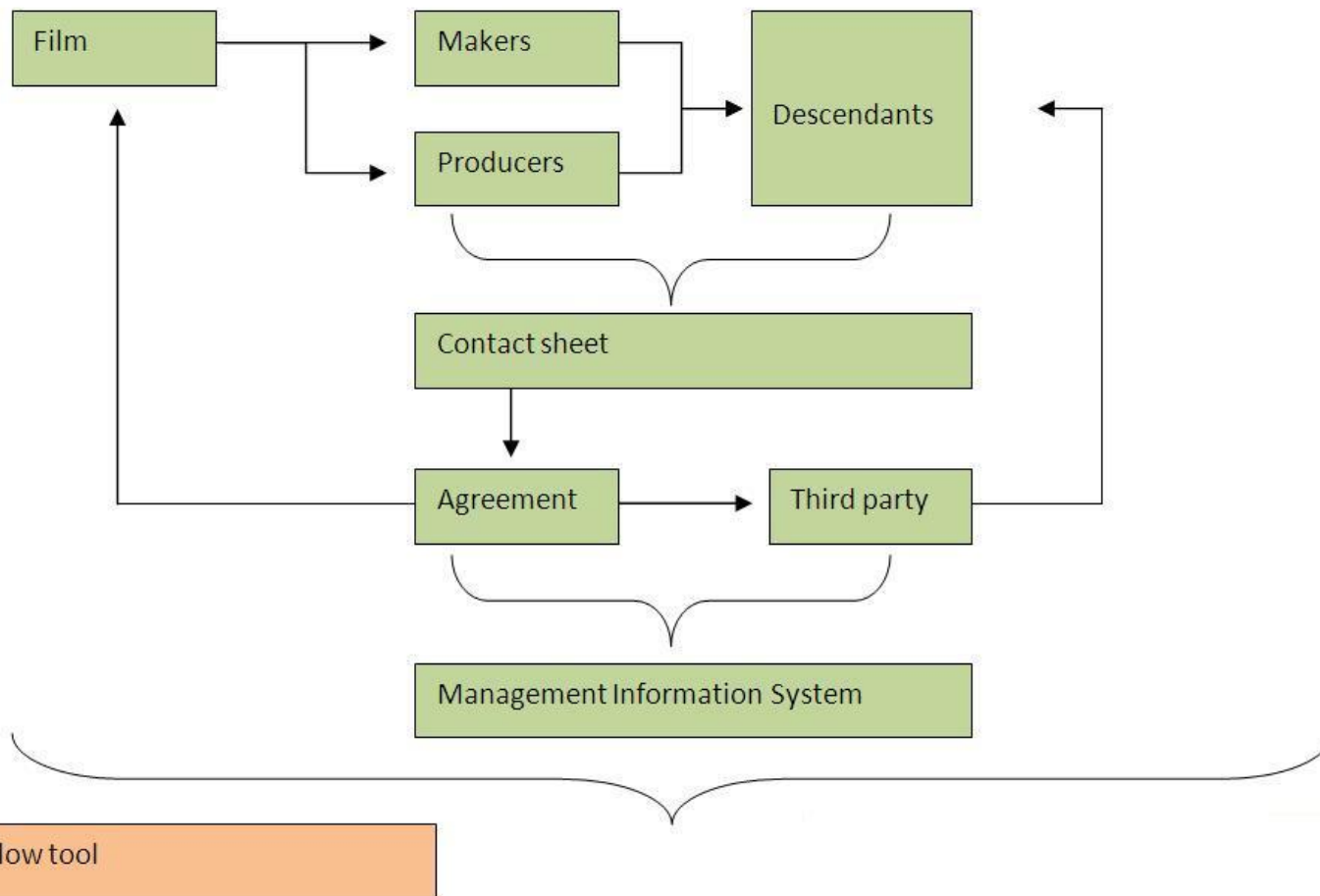

RMS: Functional Design

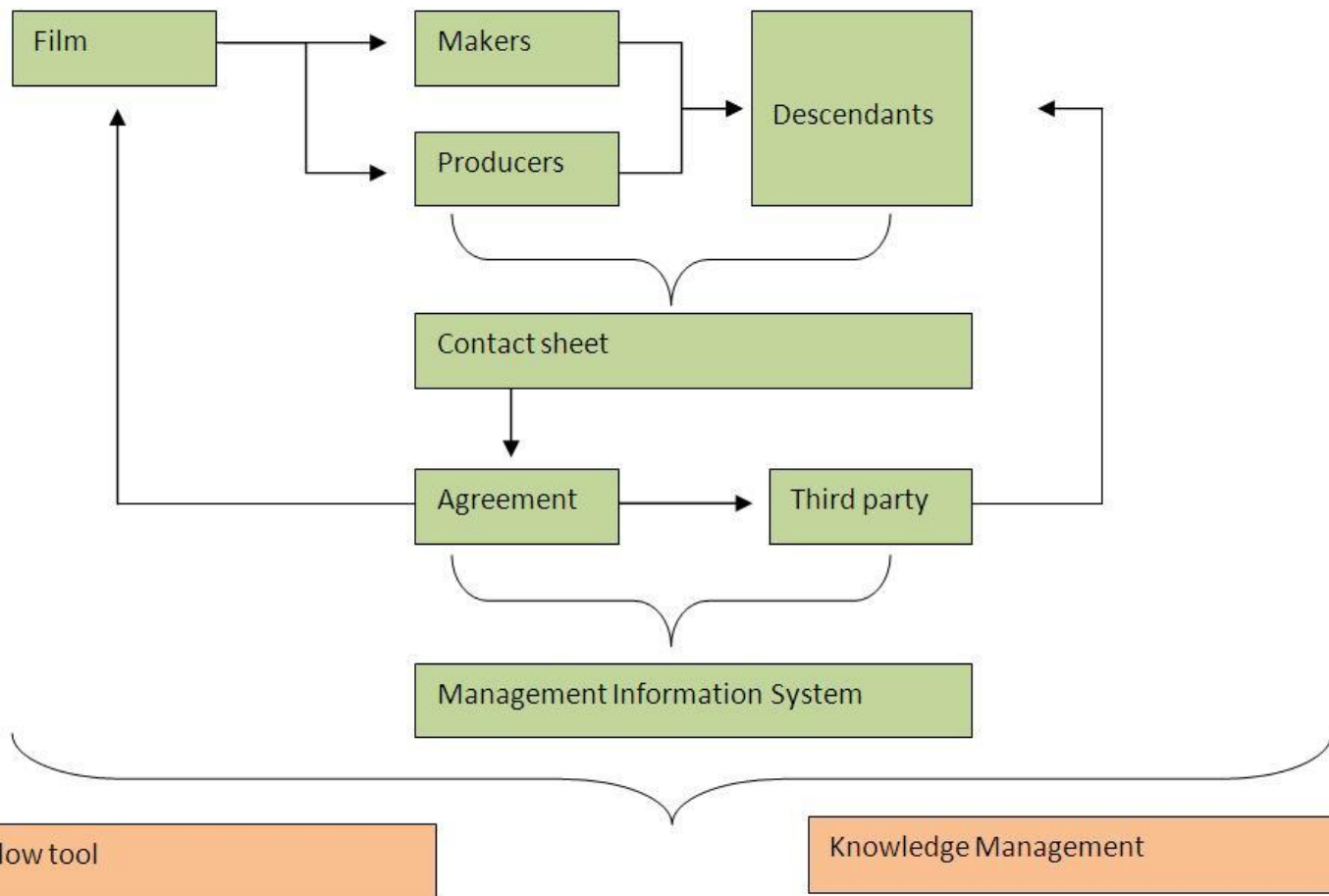

Film Clearing

THANK YOU

ericpalmen@eyefilm.nl

